

BGA5H1BN6

18dB High Gain Low Noise Amplifier for LTE Highband

Features

- Operating frequencies: 2300 - 2690 MHz
- Insertion power gain: 18.1 dB
- Insertion Loss in bypass mode: 5.2 dB
- Low noise figure: 0.7 dB
- Low current consumption: 8.5 mA
- Multi-state control: Bypass- and high gain-Mode
- Ultra small TSNP-6-10 leadless package
- RF output internally matched to 50 Ohm
- Low external component count

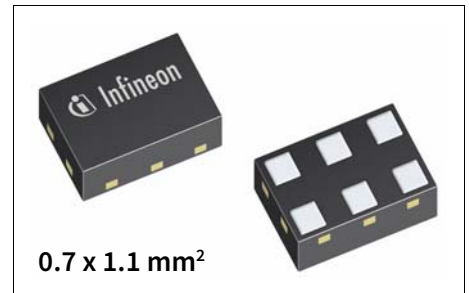

Application

The LTE data rate can be significantly improved by using the Low Noise Amplifier. The integrated bypass function increases the overall system dynamic range and leads to more flexibility in the RF front-end.

In high gain mode the LNA offers best Noise Figure to ensure high data rates even on the LTE cell edge. Closer to the basestation the bypass mode can be activated reducing current consumption.

Product Validation

Qualified for industrial applications according to the relevant tests of JEDEC47/20/22

Block diagram

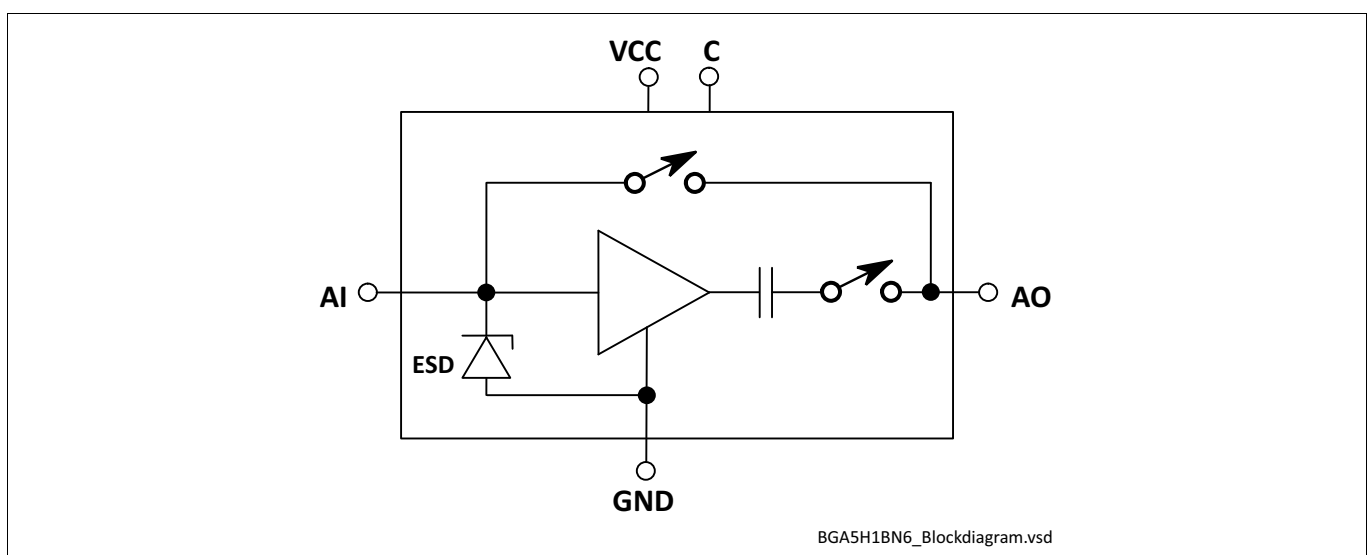

Table of Contents

| | | |
|----------|---|----------|
| | Table of Contents | 2 |
| 1 | Features | 3 |
| 2 | Maximum Ratings | 5 |
| 3 | Electrical Characteristics | 6 |
| 4 | Application Information | 8 |
| 5 | Package Information | 9 |

Features

1 Features

- Insertion power gain: 18.1 dB
- Insertion Loss in bypass mode: 5.2 dB
- Low noise figure: 0.7 dB
- Low current consumption: 8.5 mA
- Operating frequencies: 2300 - 2690 MHz
- Multi-state control: Bypass- and High gain-Mode
- Supply voltage: 1.5 V to 3.6 V
- Ultra small TSNP-6-10 leadless package (footprint: 0.7 x 1.1 mm²)
- B9HF Silicon Germanium technology
- RF output internally matched to 50 Ohm
- Low external component count
- Pb-free (RoHS compliant) package

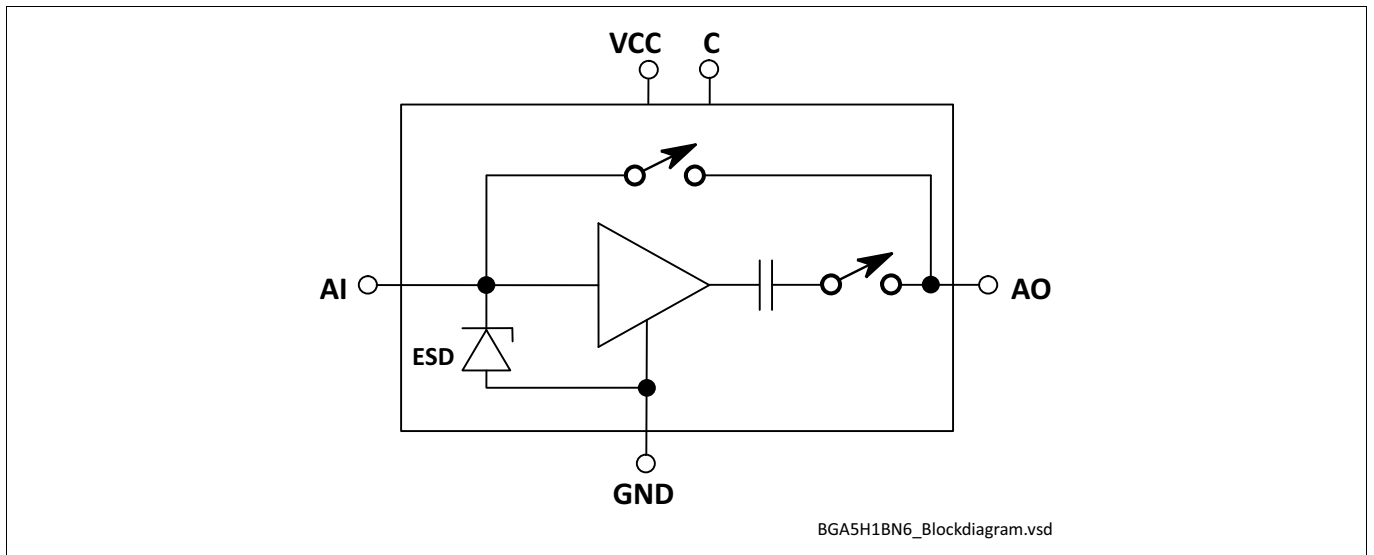
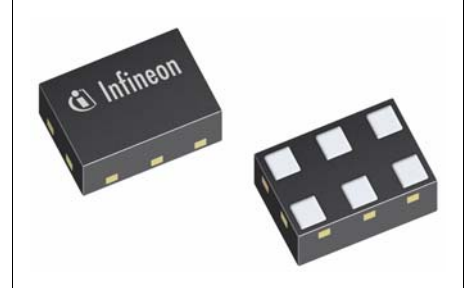

Figure 1 Block Diagram

| Product Name | Marking | Package |
|--------------|---------|-----------|
| BGA5H1BN6 | 4 | TSNP-6-10 |

BGA5H1BN6

18dB High Gain Low Noise Amplifier for LTE Highband



Features

Description

The BGA5H1BN6 is a front-end low noise amplifier for LTE which covers a wide frequency range from 2300 MHz to 2690 MHz. The LNA provides 18.1 dB gain and 0.7 dB noise figure at a current consumption of 8.5 mA in the application configuration described in [Chapter 4](#). In bypass mode the LNA provides an insertion loss of 5.2 dB. The BGA5H1BN6 is based upon Infineon Technologies' B9HF Silicon Germanium technology. It operates from 1.5 V to 3.6 V supply voltage. The device features a single-line two-state control (Bypass- and High gain-Mode). OFF-state can be enabled by powering down VCC.

Pin Definition and Function

Table 1 Pin Definition and Function

| Pin No. | Name | Function |
|---------|------|------------|
| 1 | GND | Ground |
| 2 | VCC | DC supply |
| 3 | AO | LNA output |
| 4 | GND | Ground |
| 5 | AI | LNA input |
| 6 | C | Control |

Maximum Ratings

2 Maximum Ratings

Table 2 Maximum Ratings

| Parameter | Symbol | Values | | | Unit | Note or Test Condition |
|--|-----------|--------|------|----------------|------|------------------------|
| | | Min. | Typ. | Max. | | |
| Voltage at pin VCC | V_{CC} | -0.3 | – | 3.6 | V | 1) |
| Voltage at pin AI | V_{AI} | -0.3 | – | 0.9 | V | – |
| Voltage at pin AO | V_{AO} | -0.3 | – | $V_{CC} + 0.3$ | V | – |
| Voltage at pin C | V_C | -0.3 | – | $V_{CC} + 0.3$ | V | – |
| Voltage at pin GND | V_{GND} | -0.3 | – | 0.3 | V | – |
| Current into pin VCC | I_{CC} | – | – | 16 | mA | – |
| RF input power | P_{IN} | – | – | +25 | dBm | – |
| Total power dissipation, $T_S < 148\text{ °C}^2)$ | P_{tot} | – | – | 60 | mW | – |
| Junction temperature | T_J | – | – | 150 | °C | – |
| Ambient temperature range | T_A | -40 | – | 85 | °C | – |
| Storage temperature range | T_{STG} | -55 | – | 150 | °C | – |

1) All voltages refer to GND-Node unless otherwise noted

2) T_S is measured on the ground lead at the soldering point

Attention: *Stresses above the max. values listed here may cause permanent damage to the device. Maximum ratings are absolute ratings; exceeding only one of these values may cause irreversible damage to the integrated circuit. Exposure to conditions at or below absolute maximum rating but above the specified maximum operation conditions may affect device reliability and life time. Functionality of the device might not be given under these conditions.*

Electrical Characteristics

3 Electrical Characteristics

Table 3 Electrical Characteristics $V_{CC} = 1.8V^{1)}$

$T_A = 25\text{ }^\circ\text{C}$, $V_{CC} = 1.8\text{ V}$, $V_{C,BP} = 1.8\text{ V}$, $V_{C,OFF} = 0\text{ V}$, $f = 2300 - 2690\text{ MHz}$

| Parameter | Symbol | Values | | | Unit | Note or Test Condition |
|---|----------------|--------|------|----------|---------------|---|
| | | Min. | Typ. | Max. | | |
| Supply voltage | V_{CC} | 1.5 | 1.8 | 3.6 | V | – |
| Control voltages | V_C | 1.0 | – | V_{CC} | V | High gain mode |
| | | 0 | – | 0.4 | V | Bypass mode |
| Supply current | I_{CC} | – | 8.5 | 10.3 | mA | High gain mode |
| | | – | 85 | 120 | μA | Bypass mode |
| Insertion power gain $f = 2500\text{ MHz}$ | $ S_{21} ^2$ | 16.4 | 18.1 | 19.8 | dB | High gain mode |
| | | -6.5 | -5.2 | -3.9 | dB | Bypass mode |
| Noise figure ²⁾ $f = 2500\text{ MHz}$, $Z_S = 50\ \Omega$ | NF | – | 0.7 | 1.2 | dB | High gain mode |
| | | – | 5.2 | 6.5 | dB | Bypass mode |
| Input return loss ³⁾ $f = 2500\text{ MHz}$ | RL_{IN} | 7 | 10 | – | dB | High gain mode |
| | | 5 | 8 | – | dB | Bypass mode |
| Output return loss ³⁾ $f = 2500\text{ MHz}$ | RL_{OUT} | 10 | 20 | – | dB | High gain mode |
| | | 3 | 5 | – | dB | Bypass mode |
| Reverse isolation ³⁾ $f = 2500\text{ MHz}$ | $1/ S_{12} ^2$ | 25 | 36 | – | dB | High gain mode |
| | | 3.9 | 5.2 | – | dB | Bypass mode |
| Power on time ⁴⁾⁶⁾ | t_S | – | 3 | 7 | μs | OFF to High gain mode |
| Inband input 1dB-compression point, $f = 2500\text{ MHz}^{3)}$ | IP_{1dB} | -21 | -17 | – | dBm | High gain mode |
| | | -7 | -3 | – | dBm | Bypass mode |
| Inband input 3 rd -order intercept point ³⁾⁵⁾ $f_1 = 2500\text{ MHz}$, $f_2 = f_1 \pm 1\text{ MHz}$ | IIP_3 | -12 | -7 | – | dBm | High gain mode |
| | | 1 | 6 | – | dBm | Bypass mode |
| Stability ⁶⁾ | k | > 1 | – | – | | $f = 20\text{ MHz} \dots 10\text{ GHz}$ |

1) Based on the application described in [Chapter 4](#)

2) PCB losses are subtracted

3) Verification based on AQL; not 100% tested in production

4) Gain changed to >90% of gain difference (in dB)

5) Input power HG = -30 dBm for each tone; input power BP = -10 dBm for each tone

6) Guaranteed by device design; not tested in production

Electrical Characteristics

Table 4 Electrical Characteristics $V_{CC} = 2.8V^{1)}$

$T_A = 25\text{ }^\circ\text{C}$, $V_{CC} = 2.8\text{ V}$, $V_{C,BP} = 2.8\text{ V}$, $V_{C,OFF} = 0\text{ V}$, $f = 2300 - 2690\text{ MHz}$

| Parameter | Symbol | Values | | | Unit | Note or Test Condition |
|---|----------------|--------|------|----------|---------------|---|
| | | Min. | Typ. | Max. | | |
| Supply voltage | V_{CC} | 1.5 | 2.8 | 3.6 | V | – |
| Control voltages | V_C | 1.0 | – | V_{CC} | V | High gain mode |
| | | 0 | – | 0.4 | V | Bypass mode |
| Supply current | I_{CC} | – | 9.8 | 11.6 | mA | High gain mode |
| | | – | 87 | 120 | μA | Bypass mode |
| Insertion power gain $f = 2500\text{ MHz}$ | $ S_{21} ^2$ | 16.6 | 18.3 | 20.0 | dB | High gain mode |
| | | -6.5 | -5.2 | -3.9 | dB | Bypass mode |
| Noise figure ²⁾ $f = 2500\text{ MHz}$, $Z_S = 50\text{ }\Omega$ | NF | – | 0.7 | 1.2 | dB | High gain mode |
| | | – | 5.2 | 6.5 | dB | Bypass mode |
| Input return loss ³⁾ $f = 2500\text{ MHz}$ | RL_{IN} | 7 | 10 | – | dB | High gain mode |
| | | 5 | 8 | – | dB | Bypass mode |
| Output return loss ³⁾ $f = 2500\text{ MHz}$ | RL_{OUT} | 10 | 19 | – | dB | High gain mode |
| | | 3 | 5 | – | dB | Bypass mode |
| Reverse isolation ³⁾ $f = 2500\text{ MHz}$ | $1/ S_{12} ^2$ | 25 | 36 | – | dB | High gain mode |
| | | 3.9 | 5.2 | – | dB | Bypass mode |
| Power on time ⁴⁾⁶⁾ | t_S | – | 3 | 7 | μs | OFF to High gain mode |
| Inband input 1dB-compression point, $f = 2500\text{ MHz}^{3)}$ | IP_{1dB} | -20 | -16 | – | dBm | High gain mode |
| | | -6 | -2 | – | dBm | Bypass mode |
| Inband input 3 rd -order intercept point ³⁾⁵⁾ $f_1 = 2500\text{ MHz}$, $f_2 = f_1 \pm 1\text{ MHz}$ | IIP_3 | -11 | -6 | – | dBm | High gain mode |
| | | 1 | 6 | – | dBm | Bypass mode |
| Stability ⁶⁾ | k | > 1 | – | – | | $f = 20\text{ MHz} \dots 10\text{ GHz}$ |

- 1) Based on the application described in [Chapter 4](#)
- 2) PCB losses are subtracted
- 3) Verification based on AQL; not 100% tested in production
- 4) Gain changed to >90% of gain difference (in dB)
- 5) Input power HG = -30 dBm for each tone; input power BP = -10 dBm for each tone
- 6) Guaranteed by device design; not tested in production

Application Information

4 Application Information

Application Board Configuration

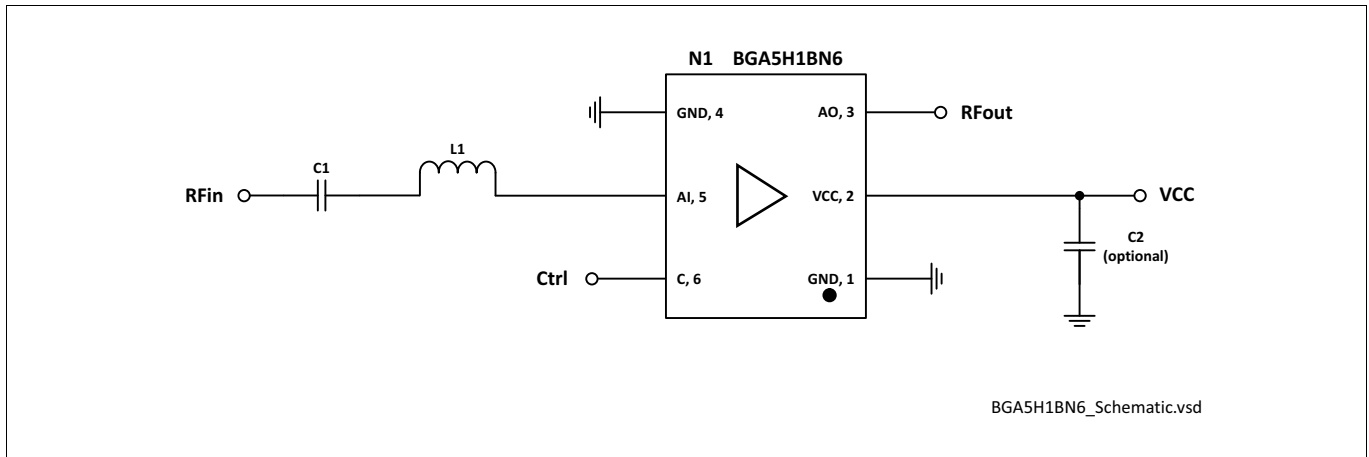

Figure 2 Application Schematic BGA5H1BN6

Table 5 Bill of Materials

| Name | Value | Package | Manufacturer | Function |
|---------------|-----------|-----------|-------------------|-------------------------|
| C1 | 1nF | 0402 | Various | Input matching |
| C2 (optional) | ≥ 1nF | 0402 | Various | RF bypass ¹⁾ |
| L1 | 3.6nH | 0402 | Murata LQW15 type | Input matching |
| N1 | BGA5H1BN6 | TSNP-6-10 | Infineon | SiGe LNA |

1) RF bypass recommended to mitigate power supply noise

A list of all application notes is available at <http://www.infineon.com/ltelna>

Package Information

5 Package Information

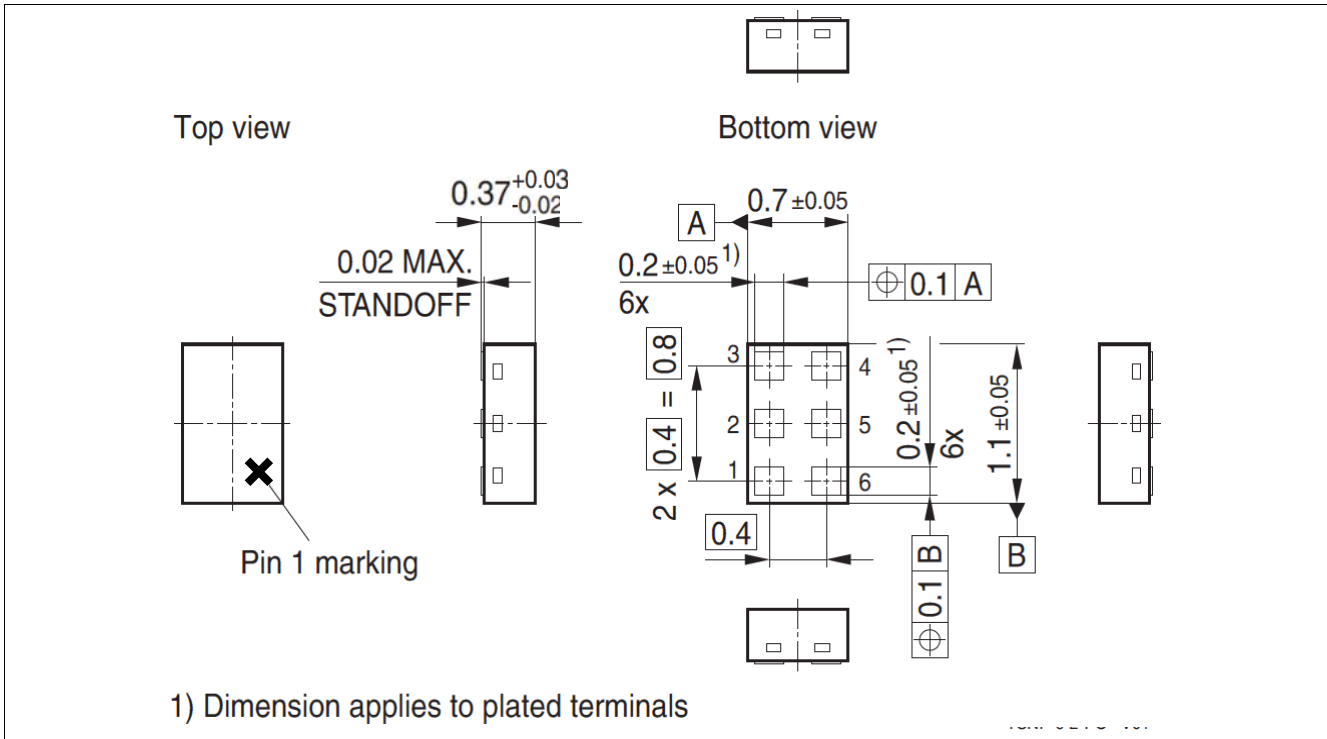

Figure 3 TSNP-6-10 Package Outline (top, side and bottom views)

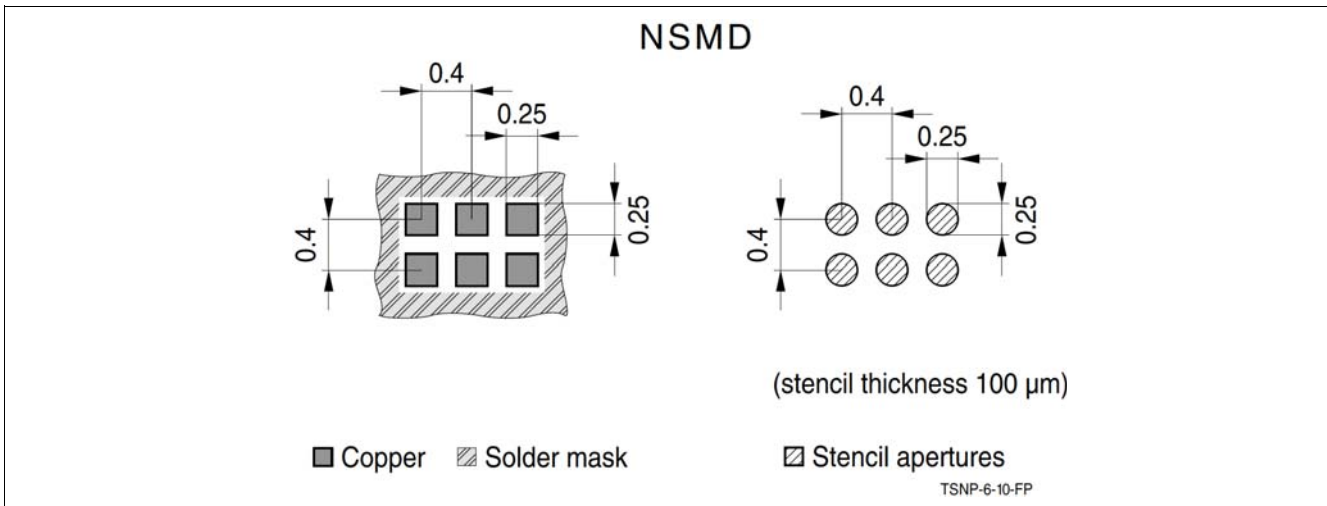

Figure 4 Footprint Recommendation TSNP-6-10

Package Information

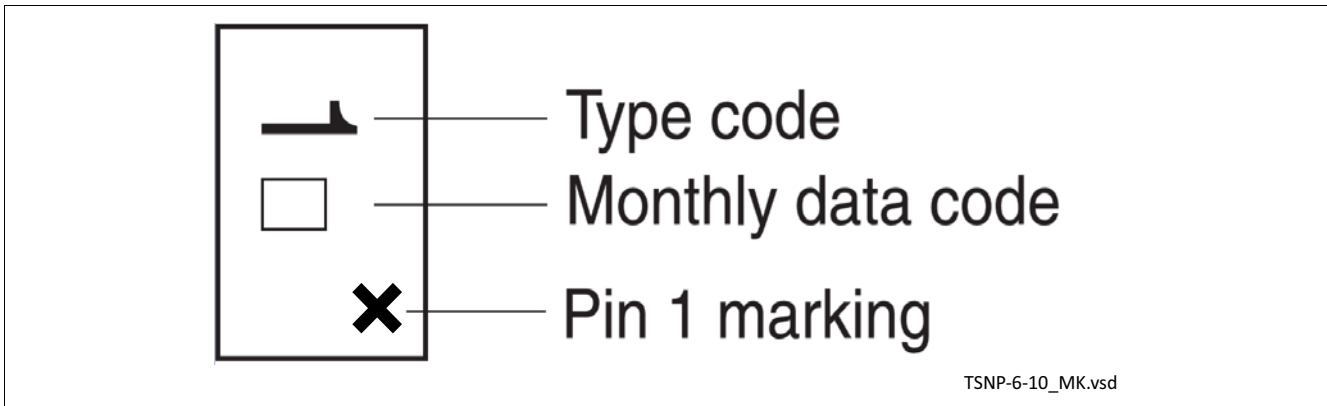

Figure 5 Marking Layout TSNP-6-10 (top view)

| Month | 2015 | 2016 | 2017 | 2018 | 2019 | 2020 | 2021 | 2022 | 2023 | 2024 | 2025 | 2026 |
|-------|------|------|------|------|------|------|------|------|------|------|------|------|
| 01 | a | p | A | P | a | p | A | P | a | p | A | P |
| 02 | b | q | B | Q | b | q | B | Q | b | q | B | Q |
| 03 | c | r | C | R | c | r | C | R | c | r | C | R |
| 04 | d | s | D | S | d | s | D | S | d | s | D | S |
| 05 | e | t | E | T | e | t | E | T | e | t | E | T |
| 06 | f | u | F | U | f | u | F | U | f | u | F | U |
| 07 | g | v | G | V | g | v | G | V | g | v | G | V |
| 08 | h | x | H | X | h | x | H | X | h | x | H | X |
| 09 | j | y | J | Y | j | y | J | Y | j | y | J | Y |
| 10 | k | z | K | Z | k | z | K | Z | k | z | K | Z |
| 11 | l | 2 | L | 4 | l | 2 | L | 4 | l | 2 | L | 4 |
| 12 | n | 3 | N | 5 | n | 3 | N | 5 | n | 3 | N | 5 |

Figure 6 Date Code Marking TSNP-6-10

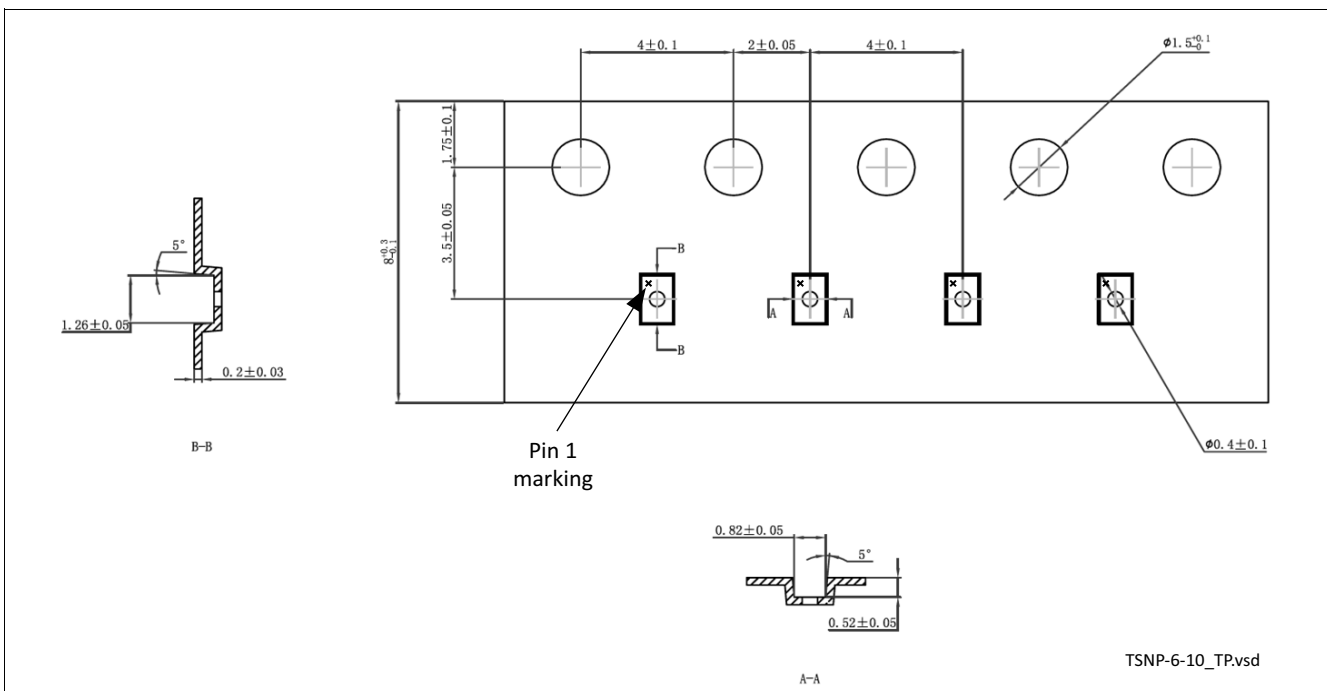

Figure 7 Tape & Reel Dimensions TSNP-6-10 (reel diameter 180 mm, pieces/reel 12000)

Revision History

| Page or Item | Subjects (major changes since previous revision) |
|---------------------------------|---|
| Revision 2.2, 2018-03-15 | |
| 5 | Update Maximum Ratings |
| | |
| | |

Other Trademarks

All referenced product or service names and trademarks are the property of their respective owners.

Edition 2018-03-15

Published by

Infineon Technologies AG

81726 Munich, Germany

© 2018 Infineon Technologies AG.

All Rights Reserved.

Do you have a question about any aspect of this document?

Email: erratum@infineon.com

IMPORTANT NOTICE

The information given in this document shall in no event be regarded as a guarantee of conditions or characteristics ("Beschaffheitsgarantie").

With respect to any examples, hints or any typical values stated herein and/or any information regarding the application of the product, Infineon Technologies hereby disclaims any and all warranties and liabilities of any kind, including without limitation warranties of non-infringement of intellectual property rights of any third party.

In addition, any information given in this document is subject to customer's compliance with its obligations stated in this document and any applicable legal requirements, norms and standards concerning customer's products and any use of the product of Infineon Technologies in customer's applications.

The data contained in this document is exclusively intended for technically trained staff. It is the responsibility of customer's technical departments to evaluate the suitability of the product for the intended application and the completeness of the product information given in this document with respect to such application.

For further information on technology, delivery terms and conditions and prices, please contact the nearest Infineon Technologies Office (www.infineon.com).

WARNINGS

Due to technical requirements products may contain dangerous substances. For information on the types in question please contact your nearest Infineon Technologies office.

Except as otherwise explicitly approved by Infineon Technologies in a written document signed by authorized representatives of Infineon Technologies, Infineon Technologies' products may not be used in any applications where a failure of the product or any consequences of the use thereof can reasonably be expected to result in personal injury.